

Features

- Drives two N-channel MOSFETs
- Operates from +5V and +12V input
- Simple single-loop control
 - Voltage-mode PWM control
- Fast transient response
 - High-bandwidth error amplifier
 - Full 0% to 100% duty ratio
- Excellent output voltage regulation
 - $\pm 1\%$ over line voltage and temperature
- TTL-compatible 5 bit digital-to-analog output voltage selection
 - Wide range $1.3V_{DC}$ to $3.5V_{DC}$
 - 0.1V binary steps from $2.1V_{DC}$ to $3.5V_{DC}$
 - 0.05V binary steps from $1.3V_{DC}$ to $2.05V_{DC}$
- Power-good output voltage monitor
- Over-voltage and over-current fault monitors
 - Does not require extra current sensing element
- Small converter size
 - Constant frequency operation
 - 200 kHz free-running oscillator programmable from 50 kHz to over 1 MHz

Applications

- Power supply for Pentium™, Pentium™ Pro, PowerPC™ and Alpha™ Microprocessors
- High-power 5V to 3.xV DC-DC regulators
- Low-voltage distributed power supplies

General Description

The AT1604 provides complete control and protection for a DC-DC converter optimized for high-performance microprocessor applications. It is designed to drive two N-channel MOSFETs in a synchronous-rectified buck topology. The AT1604 integrates all of the control, output adjustment, monitoring and protection functions into a single package.

The AT1604 includes a fully-TTL compatible 5-bit digital-to-analog converter (DAC) that adjusts the output voltage from $2.1V_{DC}$ to $3.5V_{DC}$ in 0.1V increments and from $1.3V_{DC}$ to $2.1V_{DC}$ in 0.05V steps. The precision reference and voltage-mode regulator hold the selected output voltage to within $\pm 1\%$ over temperature and line voltage variations.

The AT1604 provides simple, single feedback loop, voltage-mode control with fast transient response. It includes a 200kHz free-running triangle-wave oscillator that is adjustable from below 50kHz to over 1MHz. The error amplifier features a 12MHz gain-bandwidth product and $6V/\mu s$ slew rate which enable high converter bandwidth for fast transient performance. The resulting PWM duty ratio ranges from 0% to 100%.

The AT1604 monitors the output voltage with a window comparator that tracks the DAC output and issues a Power Good signal when the output is within $\pm 10\%$ of the targeted value. The AT1604 protects against over-current conditions by inhibiting PWM operation. Built-in over-voltage protection triggers an external SCR to crowbar the input supply. The AT1604 monitors the current by using the $r_{DS(on)}$ of the upper MOSFET, which eliminates the need for a current sensing resistor.

Block Diagram

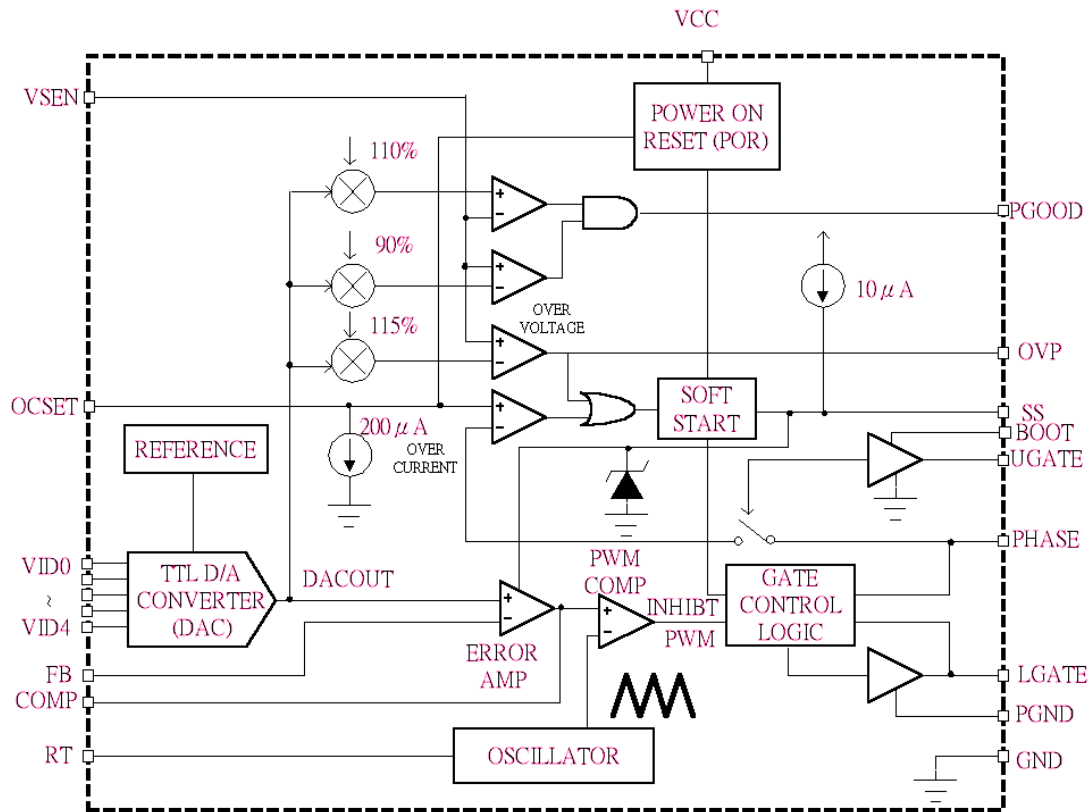

Pin Configuration

AT1604 (20-Pin SOIC)

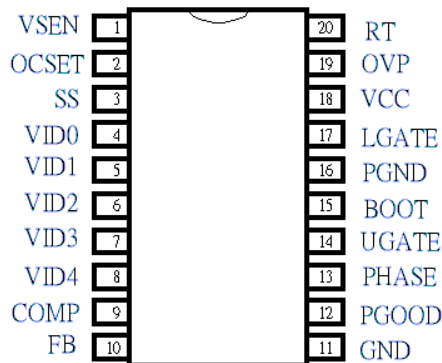

2F, No.10, Prosperity RD. II, Science-Based Industrial Park, Hsinchu 300, Taiwan, R.O.C.

Tel: 886-3-563-0878

Fax: 886-3-563-0879

WWW: <http://www.aimtron.com.tw>

Email: service@aimtron.com.tw

Preview the document, detail datasheet contact to our service department.